

# Cubii® Go

PORTABLE COMPACT ELLIPTICAL

## Owner's Manual

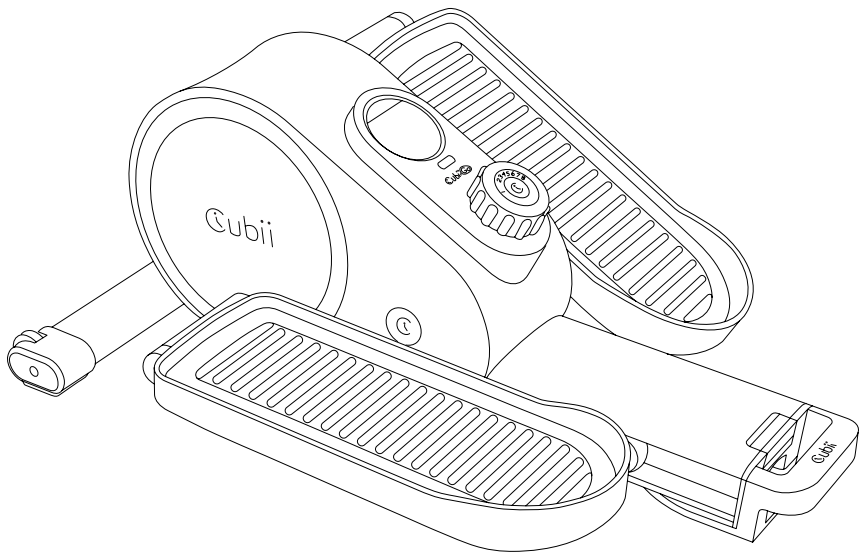



# TABLE OF CONTENTS

<b>Before You Begin</b> .....	<b>2</b>
Safety Instructions	
Consult Your Physician	
<b>Getting Started</b> .....	<b>4</b>
Warning Labels	
Serial Number Location	
<b>Using Your Cubii Go</b> .....	<b>5</b>
Transporting	
Product Size and Weight	
Positioning	
Display Monitor	
Adjusting the Resistance	
Using the Chair Wheel Cup	
<b>General Information</b> .....	<b>9</b>
LCD Screen Battery Caution & Disposal	
Battery Replacement	
Care and Maintenance	
Regulatory Notices	
Important Health & Safety Instructions	
Troubleshooting	
Return Policy and Warranty	



# Welcome to the Cubii Community!

Whether you are taking the first step on your fitness journey or looking to get more exercise from the comfort of home, bringing the Cubii Go into your routine is a big stride toward a healthier, more active life! Before you begin, we want you to be familiar with important information on how to use Cubii Go safely so that you and your loved ones get the most out of your experience. Let's review the safety notes and warnings now. If you have any questions, please contact:

1-844-282-4401

[support@mycubii.com](mailto:support@mycubii.com)

[cubii.com/support](https://cubii.com/support)

# BEFORE YOU BEGIN

## Safety Instructions

**WARNING** Consult your physician before starting this or any exercise program. This is especially important if you have never exercised before, are pregnant, or suffer from any health problem. If at any time during exercise, you feel faint, dizzy, or experience pain, stop and consult your physician.

**WARNING** Do not use when standing. Only use when sitting. Failure to follow all warnings and instructions could result in serious injury or death.

**WARNING** To reduce the risk of serious injury, read the following Safety Instructions before using Cubii Go.

1. Read all warnings and cautions posted on the Cubii Go unit.
2. Cubii Go should only be used after a thorough review of the Owner's Manual.
3. We recommend that two people are available for the unboxing of this product.
4. Do not allow children to use or play on Cubii Go. Keep children and pets away from Cubii Go when it is in use.
5. Set up and operate Cubii Go on a solid, level surface. Do not position Cubii Go on loose rugs or uneven surfaces.
6. Make sure that adequate space is available for access to and around Cubii Go.
7. Before using, inspect Cubii Go for worn or loose components, and securely tighten or replace any worn or loose components prior to use.
8. Follow your physician's recommendations in developing your own personal fitness program.

9. Always choose a workout plan which best fits your fitness and ability level. Know your limits and train within them. Always use common sense when exercising.
10. Do not wear loose or dangling clothing while using Cubii Go.
11. Be careful to maintain your balance on your chair while using, mounting, dismounting, or assembling Cubii Go; loss of balance may result in a fall and serious bodily injury.
12. Keep both feet firmly and securely on the pedals while exercising.
13. Maximum recommended user weight is 300 pounds (136 kg).
14. Cubii Go should be used by only one person at a time.

**USE ONLY WHILE SITTING, DO NOT STAND  
ON THE UNIT UNDER ANY CIRCUMSTANCE.**

## **Consult Your Physician**

It is always important to consult your physician before starting an exercise program. This is particularly true if any of the following apply to your current medical condition:

- Chest pain or pain in the neck and/or arm
- Shortness of breath
- A diagnosed heart condition
- Joint and/or bone problems
- Currently taking cardiac and/or blood pressure medications
- Have not previously been physically active
- Dizziness or blurred vision
- Those with physical handicaps

If none of these apply to you, start gradually and sensibly. However, if you feel any of the physical symptoms listed above when you start your exercise program, contact your physician right away.

# GETTING STARTED

## Warning Labels

The warning label is located on your Cubii Go product here:

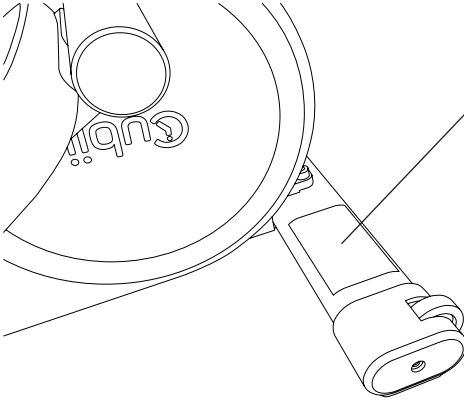

### WARNING

Failure to follow all warnings and instructions could result in serious injury or death. Before assembling or using this product, read and follow the Product Manual and all other instructions that accompany this product. Replace this warning label if damaged, illegible, or removed.

**Keep others including children and pets away from equipment when in use.**  
Consult your physician before starting this or any exercise program. This is especially important if you are over the age of 35 or have any pre-existing health condition. Always make sure all nuts and bolts are securely tightened before using this product.

**DO NOT USE WHILE STANDING. USE ONLY WHEN SITTING.  
STANDING ON THE UNIT MAY CAUSE SERIOUS INJURY.**

## Serial Number Location

The serial number is located on your Cubii Go product here:

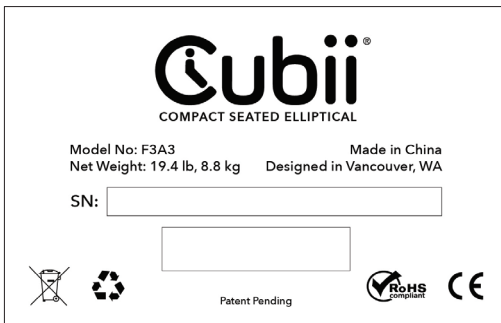

**Cubii®**

COMPACT SEATED ELLIPTICAL

Model No: F3A3

Made in China

Net Weight: 19.4 lb, 8.8 kg    Designed in Vancouver, WA

SN:



Patent Pending

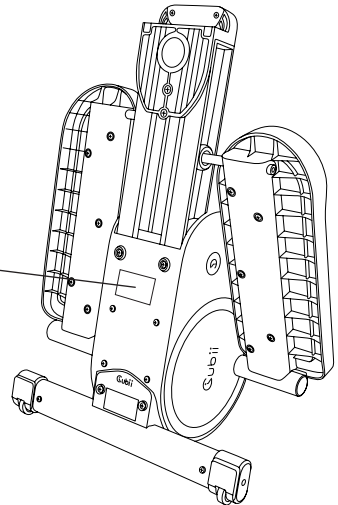

Record your serial number here for future reference: \_\_\_\_\_



# USING YOUR CUBII GO

## Transporting

The Cubii Go features an extendable handle and roller wheels which allow the unit to be rolled across the floor, much like a rolling suitcase. To do this, follow these steps:

1. Extend the handle by holding down the handle release button, then pull the handle out fully, about 8" (20cm).
2. Lift the handle to angle the unit and roll it to the desired position.
3. To collapse the handle, press the handle release button and slowly return the handle to the desired position. (Once you have started collapsing the handle, you can stop pressing the button.)
4. Lower Cubii Go to the ground in the desired position.

The unit can also be stood on end and lifted up to carry like a briefcase.

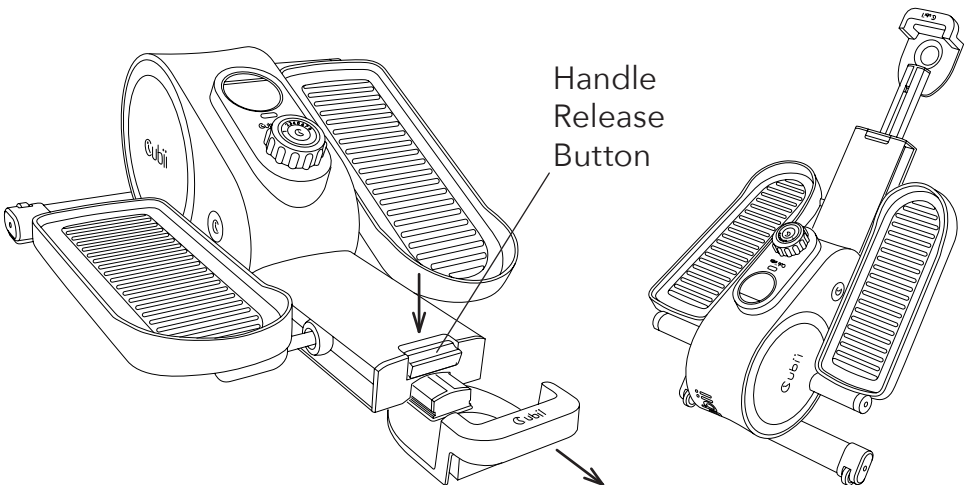

## Product Size and Weight

The assembled Cubii Go measures:

24.5"L x 17.25"W x 9"H (624 x 438 x 227mm)

The weight of the unit is approximately 19.4lb (8.8kg).

## Positioning

The Cubii Go can be used either in an upright position, such as with an office chair, or in a more reclined position, such as when placed in front of a sofa.

- Cubii Go occupies a floor area of 20.7" x 17.8" (0.53m x 0.45m). Please leave a clear zone behind the training area that is at least 0.6m (24"). This zone must be clear of any obstruction and provide the user a clear exit path.
- Find the seat configuration that suits you most. If you feel there is not enough room between your knees and the desk, push your Cubii Go away from you and lower the chair height. Keep your back straight, and do not slouch.
- If you are sitting on an office chair with wheels, you are encouraged to use the wheel cup.

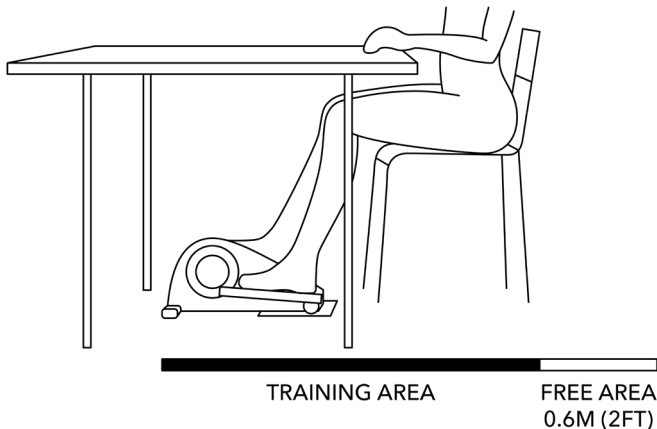

## Display Monitor

To wake up the display, press the colored button under the display. The top line shows stride count. (A stride is one complete 360 degree revolution.)

The bottom line can cycle between Time, Calories, Distance, and RPM. In Scan mode, the display will automatically cycle through these metrics.

To reset stats, press and hold the button until all segments turn black (about 3 seconds), then let go. Replacing the battery will also reset the stats. When the stats reach maximum values, they will reset to zero.

To switch from Miles(MI) to Kilometers(KM), press and hold the silver button for at least 6 seconds. All segments will turn black twice during this time. After the second flash of black segments, release the button. When displaying distance, you will see the MI is now showing a KM, or vice versa.

## Adjusting the Resistance

Cubii Go comes with 8 levels of resistance. Turn the knob clockwise to increase the resistance. The higher the number, the higher the resistance. We highly recommend you begin at Level 1 and increase the intensity gradually over time.

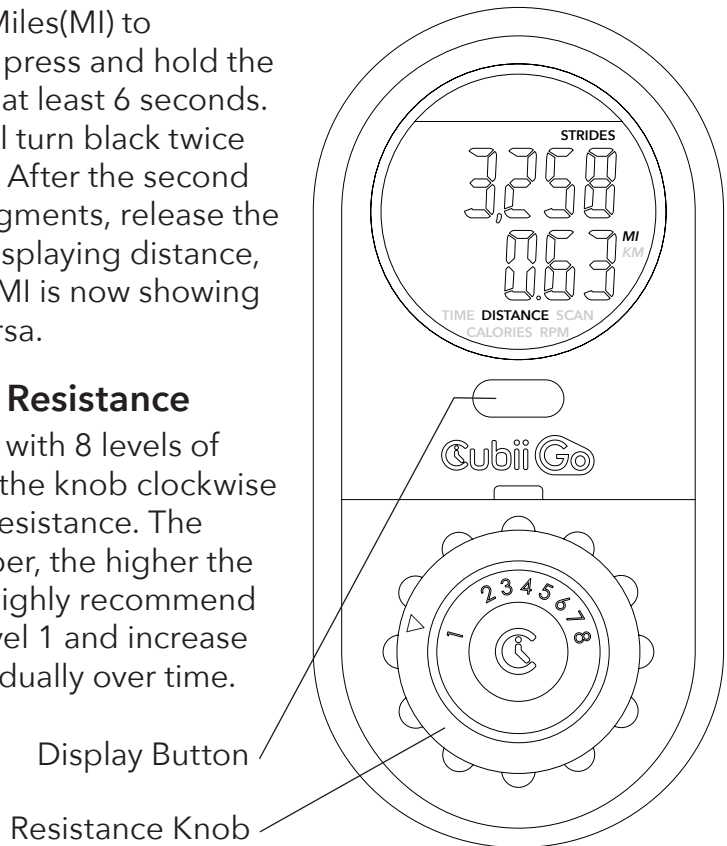

## Using the Chair Wheel Cup

If you're using Cubii Go while sitting in a chair with wheels or castors, your chair may move during use. If this is happening, follow the steps below:

Extend the handle by at least 1 position to expose the wheel cup. To do this, press and hold down the Handle Release Button while pulling out the handle, about 2.2" (56mm). If you wish to use the Go in a more reclined position, you may extend the handle to the 2nd stop. Roll the wheel from your chair into the wheel cup.

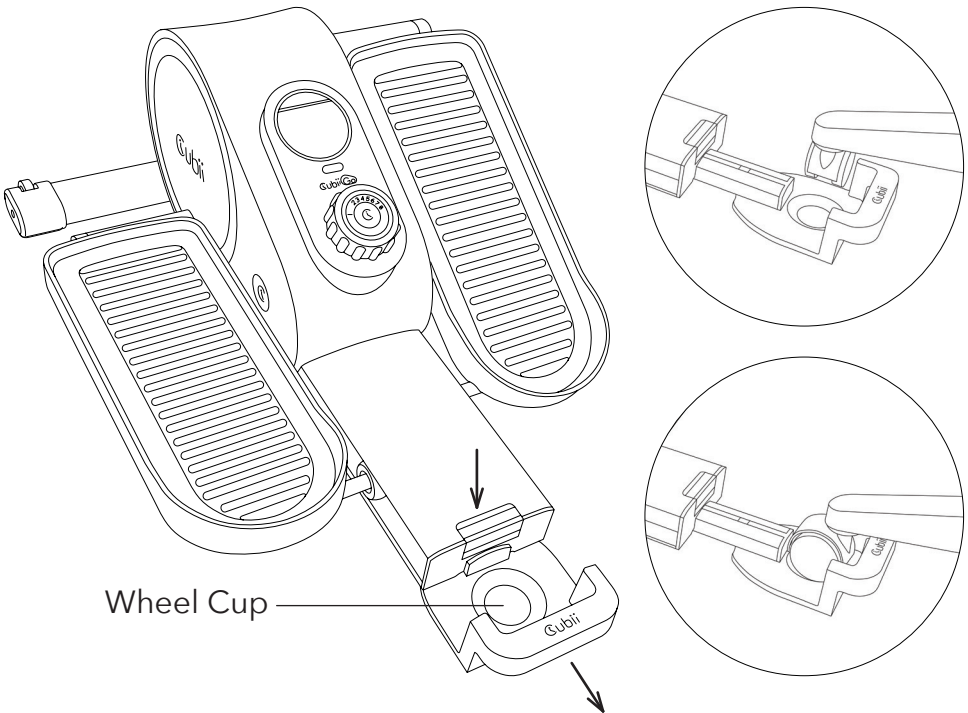

# GENERAL INFORMATION

## LCD Screen Battery Caution & Disposal

For best results, use two (2) - 1.5V LR03 Alkaline AAA batteries when replacing the old batteries. Install only new batteries of the same type. Failure to insert batteries in the correct polarity may shorten the life of the battery, cause the console unit to become inoperable, or cause the batteries to leak.

## To Replace Batteries

1. Use a flat screwdriver to gently pry the screen from the housing using the recessed space above the resistance dial.

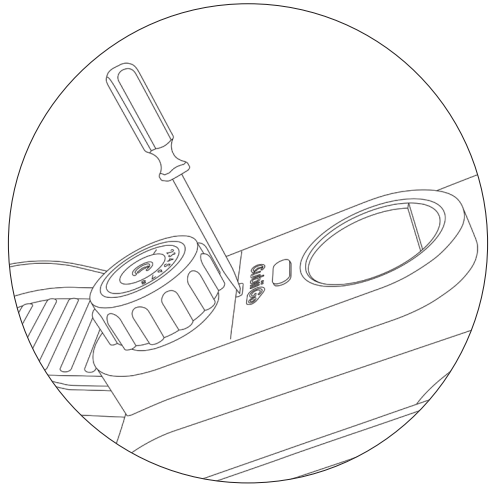

2. Lift and remove the screen straight out of the housing.

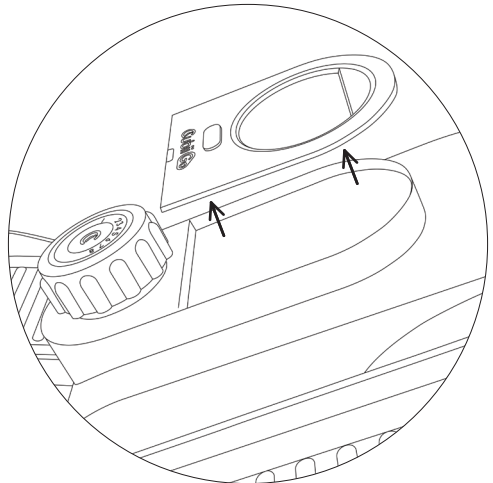

#### IV. General Information

3. Replace the batteries with the polarities oriented in the directions indicated below.

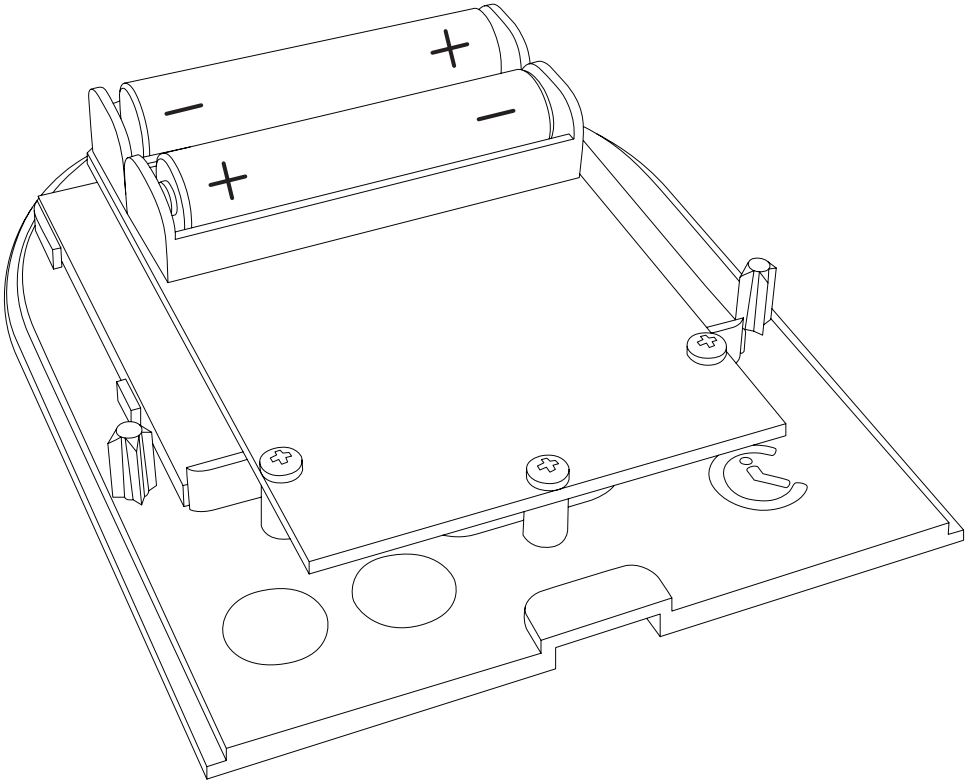

**NOTE:** Ultimate disposal of the battery should be handled according to all state and federal laws and regulations. Do not dispose of batteries in fire.

## Care and Maintenance

The safety and integrity designed into Cubii Go can only be maintained when Cubii Go is regularly examined for damage and wear. It is the sole responsibility of the user/owner to ensure that regular maintenance is performed. Special attention should be given to the following:

- Periodically wipe the unit down with a damp cloth, paying special attention to the metal surface of the wheel tracks. This will help reduce any noise between the wheels and the wheel track.
- Worn or damaged components shall be replaced immediately or Cubii Go removed from service until repair is made. Email Fitness Cubed Inc at [support@mycubii.com](mailto:support@mycubii.com) to request replacement parts.
- Only Fitness Cubed Inc supplied components shall be used to maintain/repair Cubii Go.

**USE ONLY WHILE SITTING, DO NOT STAND ON THE UNIT UNDER ANY CIRCUMSTANCE.**

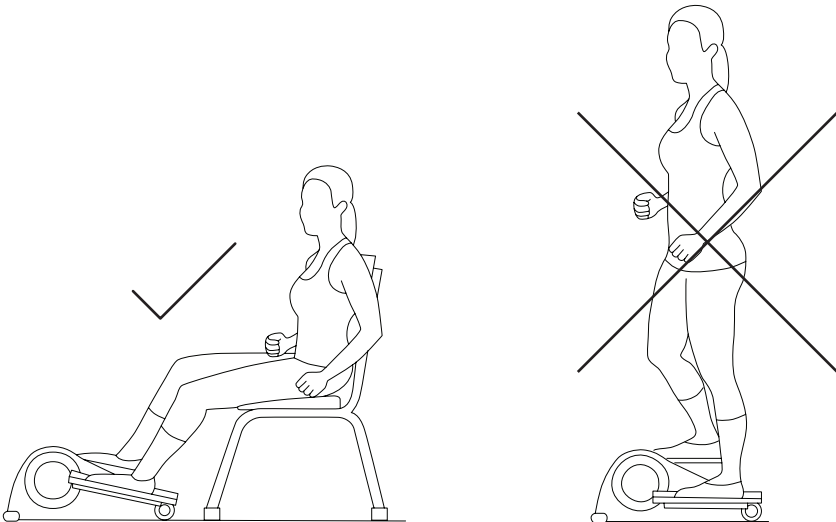

## Regulatory Notices

### EU (European Union)

Declaration of Conformity with Regard to the EU Directive 2014/53/EU  
Fitness Cubed Inc is authorized to apply the CE Mark on Cubii Go, Model F3A3, thereby declaring conformity to the essential requirements and other relevant provisions of Directive 2014/53/EU

Compliant with the standard R&TTE 2014/53/EU

Conforme à la norme R&TTE 2014/53/EU

## Important Health & Safety Instructions

Read and follow these instructions:

- Cubii Go has been designed to be used only while sitting. Do not stand on the pedals as it was not designed to be used while standing.
- Do not subject Cubii Go to heavy shock or treat it excessively. Do not attempt to disassemble or modify it.
- Use Cubii Go indoors on a level surface. Keep it away from moisture and dust.
- Do not expose Cubii Go to extremely high or low temperatures. Do not leave Cubii Go in direct sunlight for an extended period of time.
- Do not place Cubii Go in a location where it may cause an obstruction.
- Do not use cleaners or solvents to clean Cubii Go.
- Do not use any lubricants. They can damage the unit.

Consult your physician before starting this or any exercise program. This is especially important if you are over the age of 35 or have any pre-existing health condition. If you feel faint or dizzy, immediately discontinue use of this equipment. Serious bodily injury can occur if this equipment is not assembled and used correctly. Serious bodily injury can also occur if all instructions are not followed. Keep others and pets away from equipment when in use. Follow all safety instructions in this manual.



## **Troubleshooting**

For troubleshooting and assistance with your Cubii Go, you can email us at: [support@mycubii.com](mailto:support@mycubii.com)

## **Return Policy and Warranty**

The warranty for the Cubii Go is 1 year from date of purchase. To register for your warranty, visit:  
<https://www.cubii.com/pages/register>

Cubii Go Return Policy can be found online at:  
<https://www.cubii.com/policies/refund-policy>



**Customer Support**

support@mycubii.com

cubii.com/support

1-844-282-4401